

022..  
023..  
026..  
168..  
168D..  
161..  
302

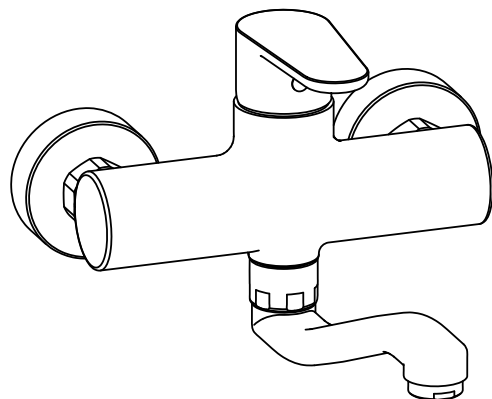

Montaggio  
Assembly

1

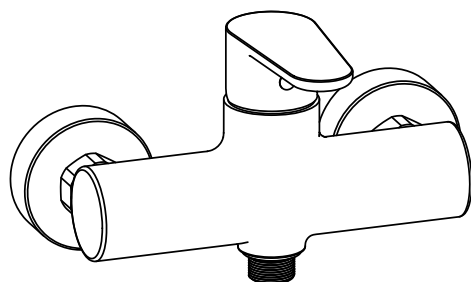
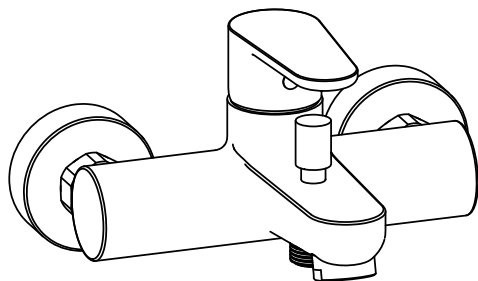
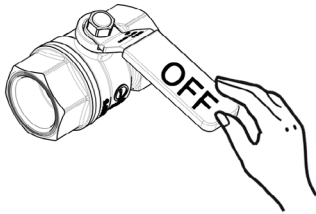

$65 \pm 5^\circ\text{C}$



$15 \pm 5^\circ\text{C}$

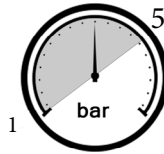

1

MIN - MAX

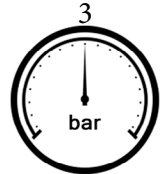

3

OK

2

161 022

168 023

168D 026

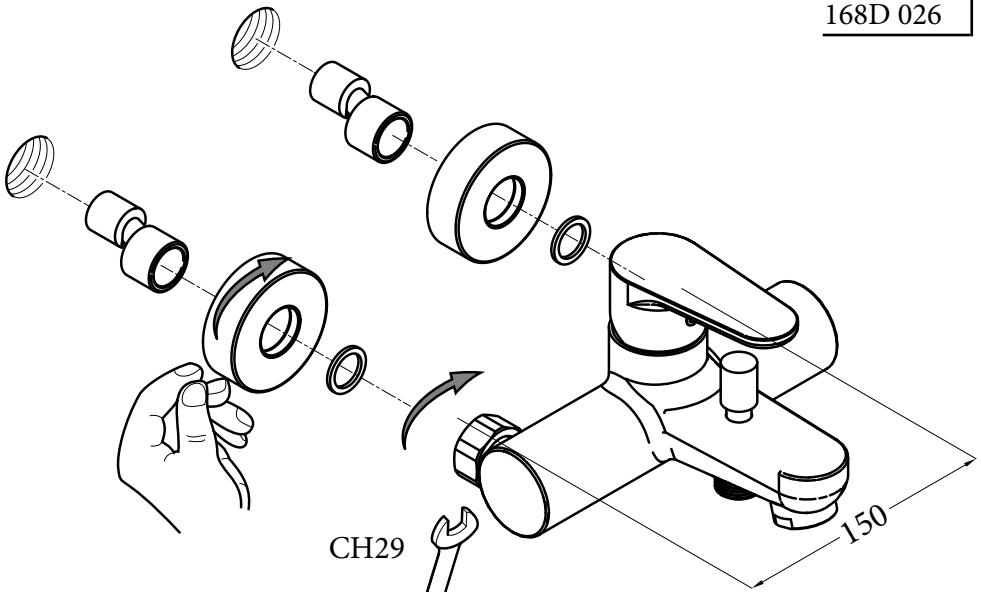

4

168D  
023

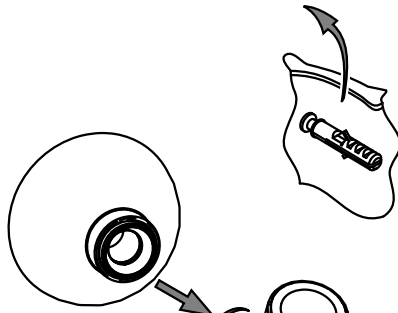

023  
168D

026

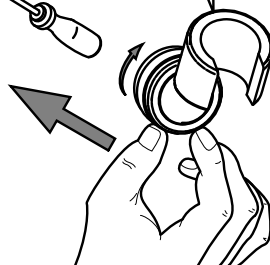
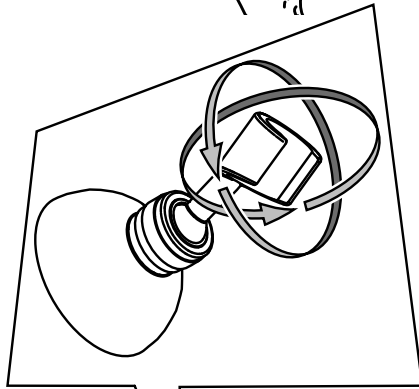
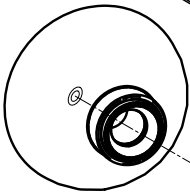
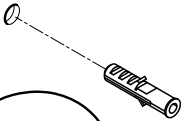
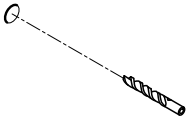
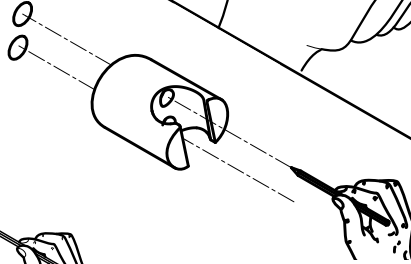
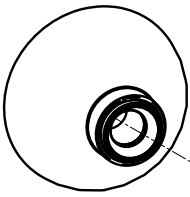

Deviatore  
Diverter

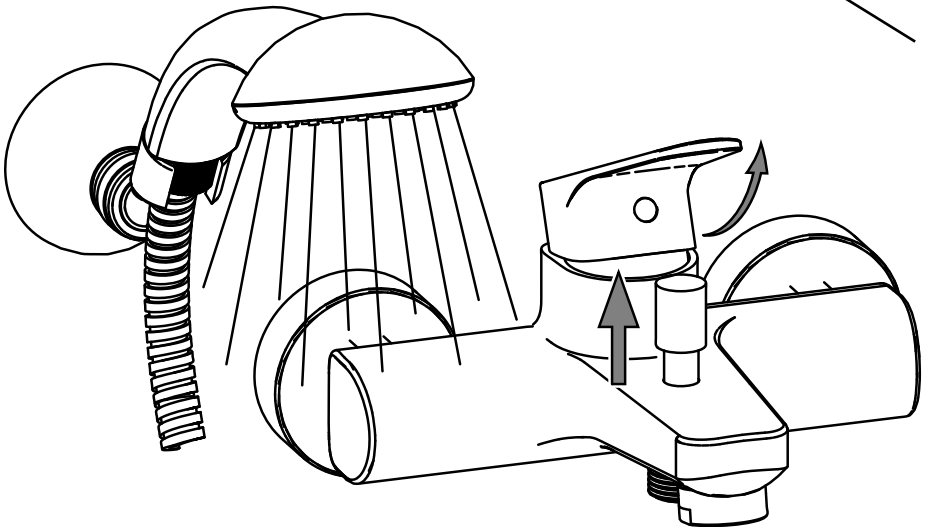
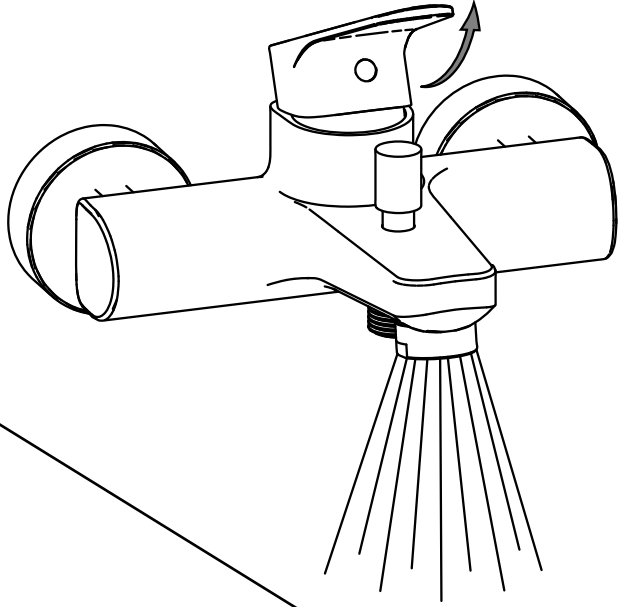

**3**

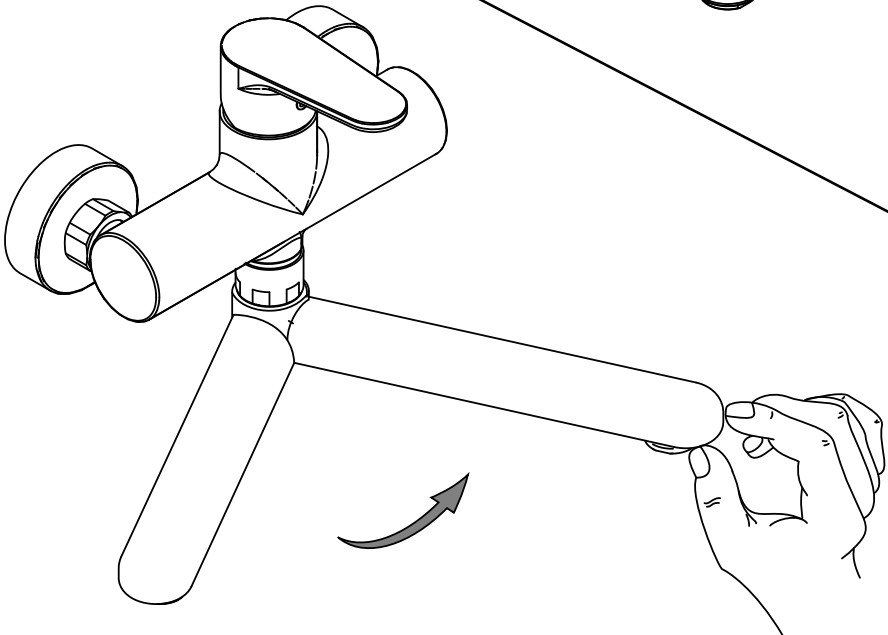
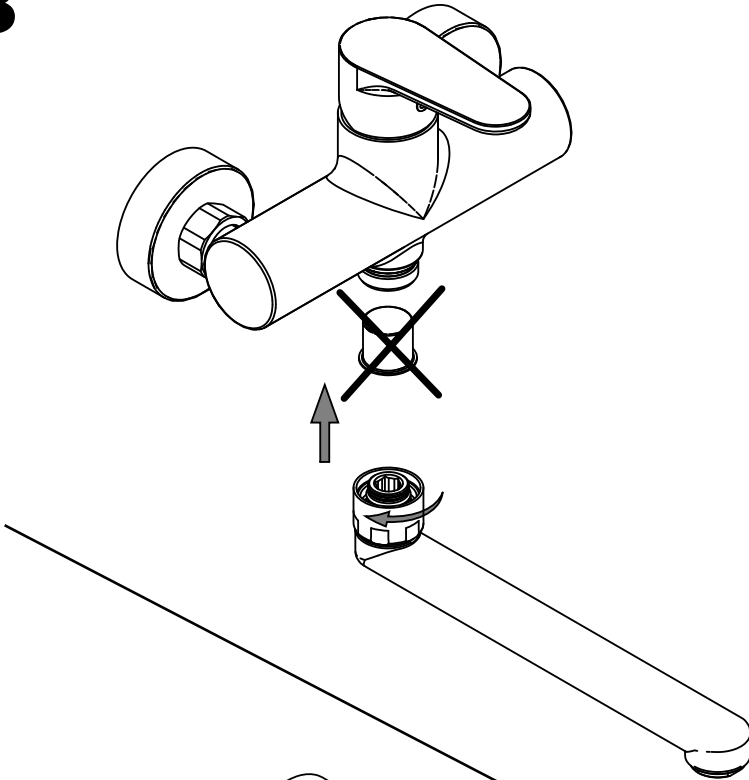

# M

## Manutenzione Service

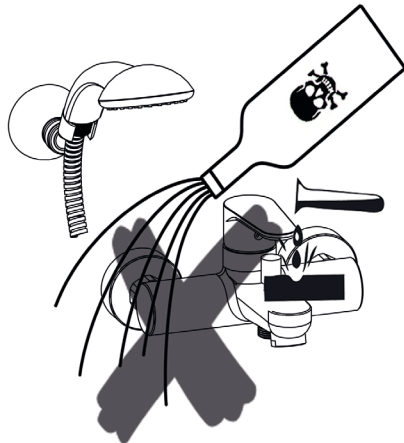
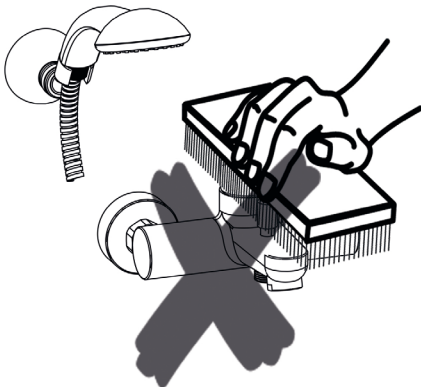
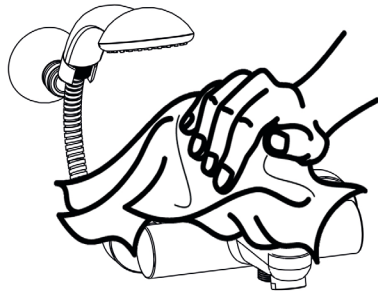
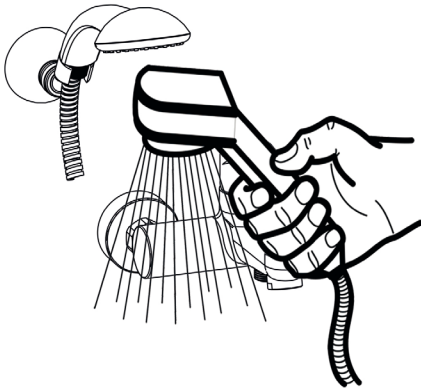
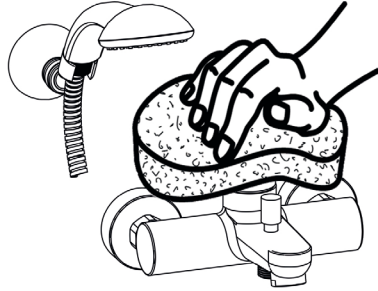
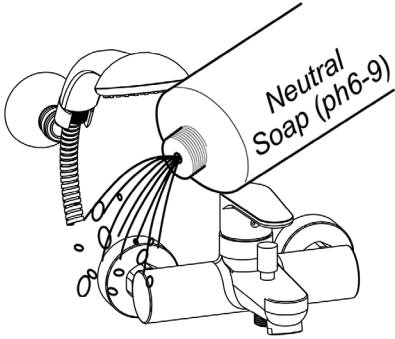

**S**

Sostituzione Cartuccia  
How to replace Cartridge

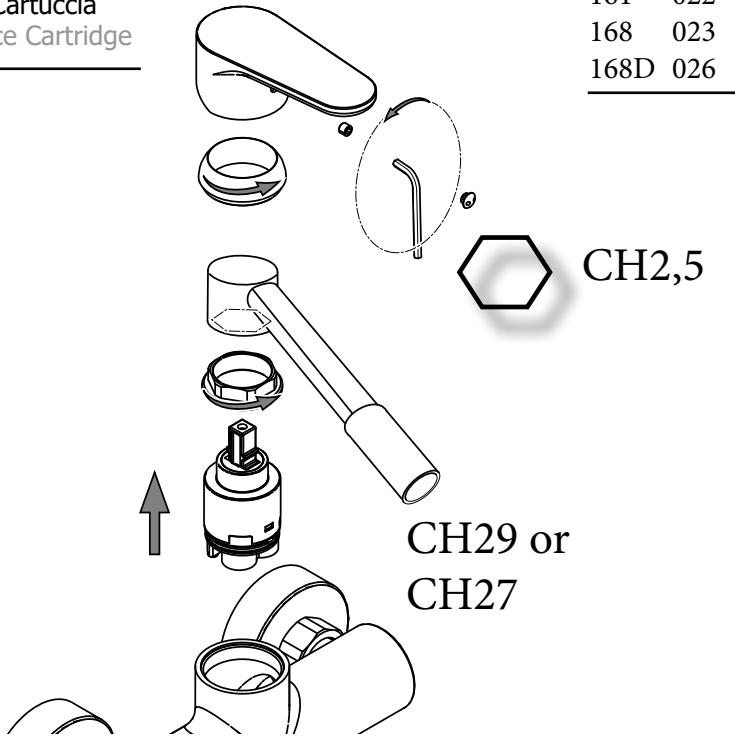
**a****b**

Sostituzione Sede Calotta  
How to replace Seat for Nut

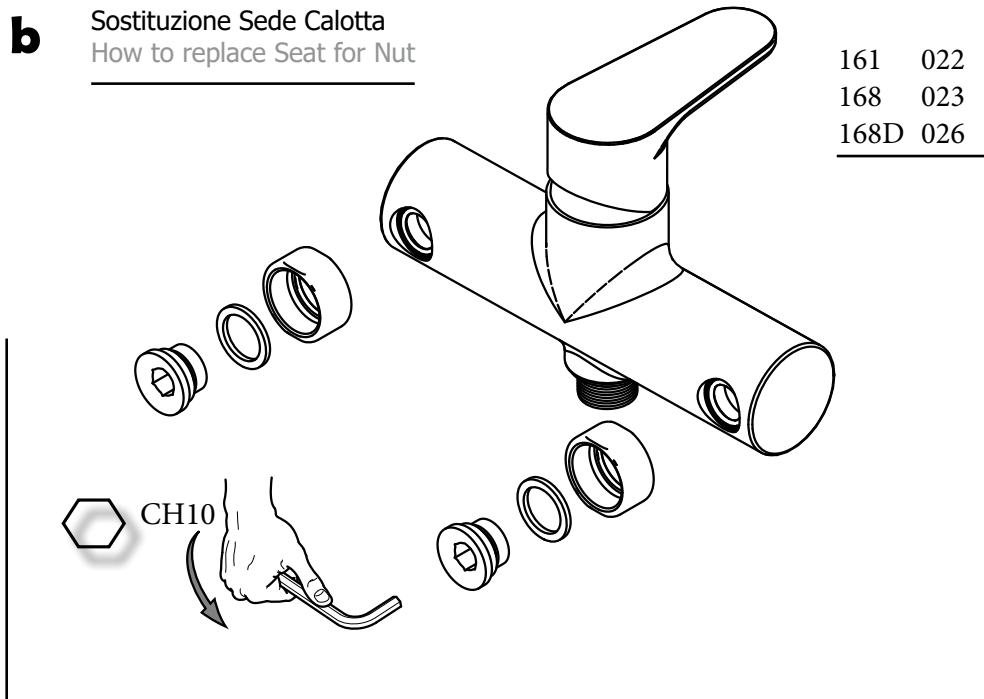

**c** Sostituzione Deviatore  
How to replace Diverter

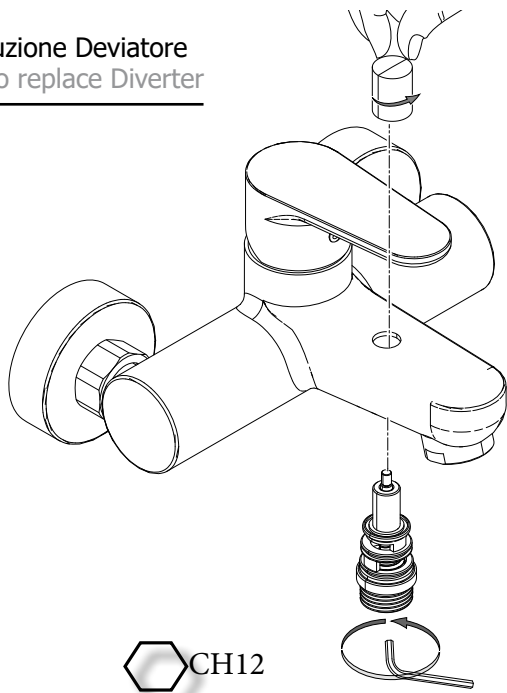

022

023

026

**d** Sostituzione Aeratore  
How to replace Aerator

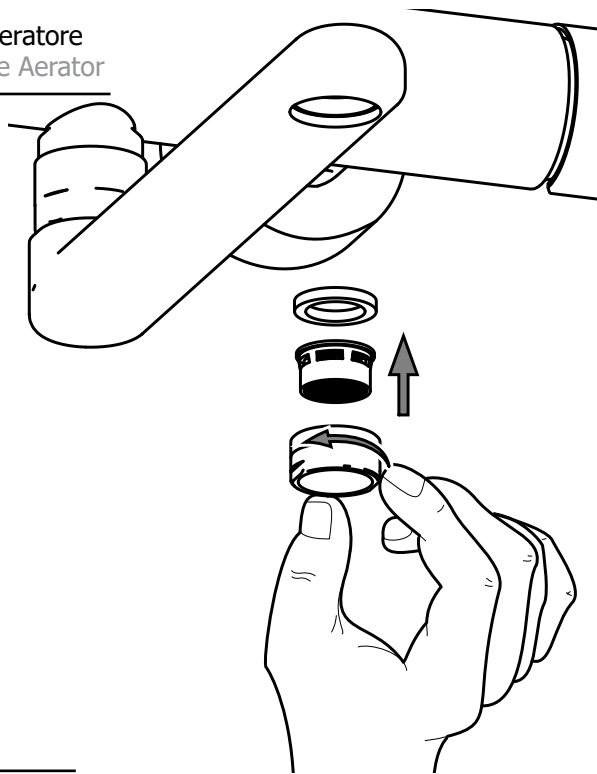

161

022

023

026